

NEXUS™ 96G

Operating Manual



IMPORTANT NOTE:

THE BIN MUST BE SITED ON LEVEL GROUND TO ENSURE CORRECT ALIGNMENT OF THE DOOR AND BODY. IF YOU ARE NOT USING GLASDON FIXINGS YOU MUST ENSURE THAT 2" DIAMETER WASHERS ARE USED IN ORDER TO SECURE THE BIN WHEN GROUND FIXING.
CONCRETE FIXING KIT INCLUDED.



NOTE: ENSURE THAT ALL RELEVANT PERSONNEL READ THE POINTS LISTED WITHIN THIS LEAFLET AND THAT A COPY IS GIVEN TO STAFF INVOLVED WITH THE INSTALLATION AND MAINTENANCE OF THIS PRODUCT

Opening/Closing Bin

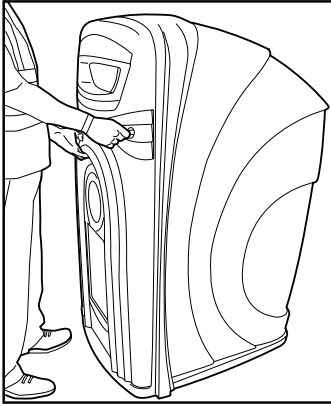

1. Insert key into key hole and place left hand into handle recess as shown.

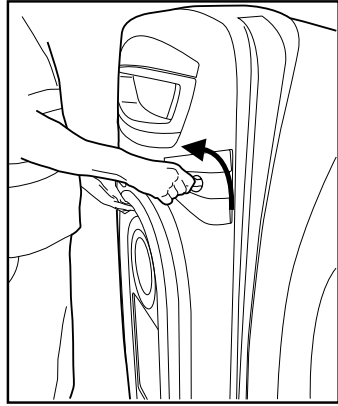

2. Turn key anticlockwise until it stops.

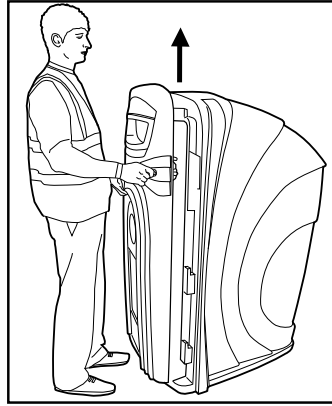

3. Using handle lift door and allow door to pivot open.

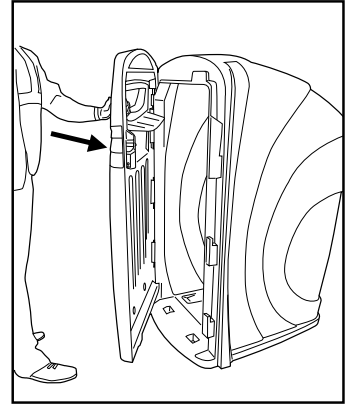

4. Slam door to shut.

Inserting Toter Cart

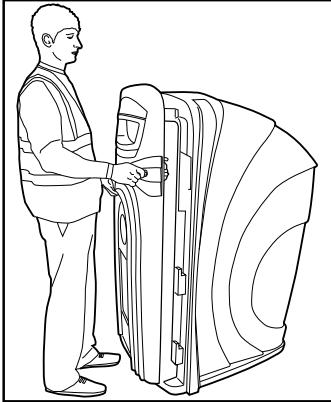

1. Open the door. (See above for details.)

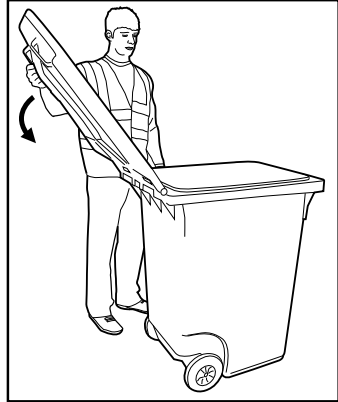

2. Open the lid of the wheeled bin.

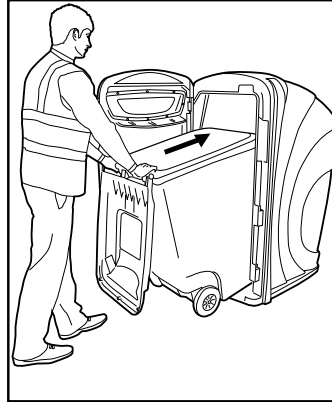

3. Push the wheeled bin into the housing so that the wheels sit in the location points within the base.

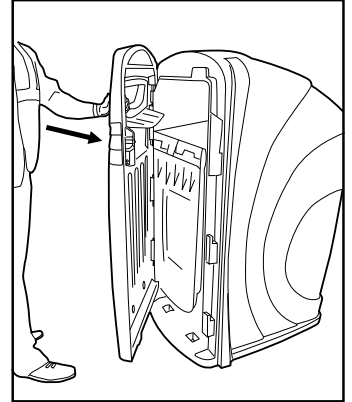

4. Slam door to shut.

Removing Toter Cart

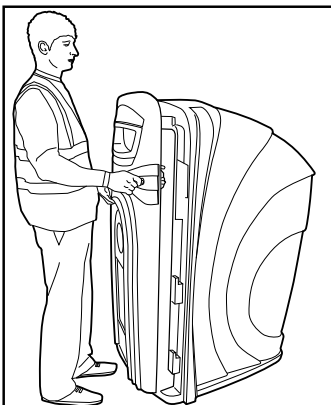

1. Open the door. (See above for details.)



2. Using the handles pull the wheeled bin out of the housing.

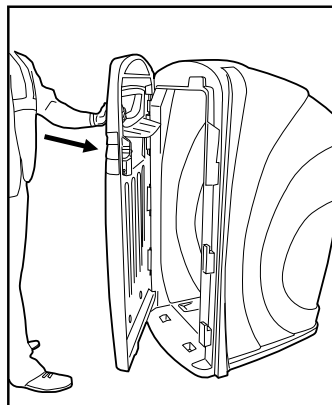

3. Slam door to shut.

NEXUS™ 96G

Operating Manual

Inserting/Removing Poster (Accepts LAMINATED large paper/card with a visible viewing area of 14" x 10½")

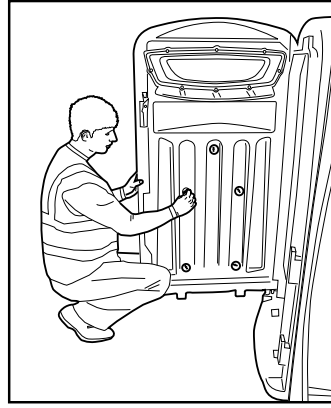
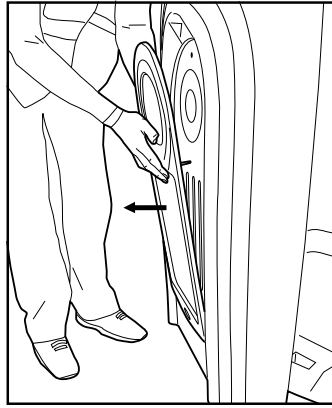
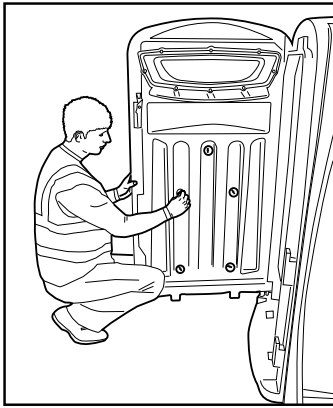

1. Remove all five wingnuts and washers from the inside of the bin by unscrewing anticlockwise.

2. From outside the bin, remove the frame and insert/replace poster behind the clear panel.

3. Place frame back into position and tighten wingnuts from inside the bin to secure.

IMPORTANT NOTE: Do not over tighten wingnuts.

INSTRUCTIONS FOR CONCRETE FIXING KIT (INTO PREPARED CONCRETE FOUNDATION)

IMPORTANT NOTE: TO ENSURE A SECURE AND ROBUST INSTALLATION THE BIN SHOULD BE SITED ONTO A SOUND CONCRETE FOUNDATION AND THE 50MM DIAMETER WASHER MUST BE USED. WE STRONGLY RECOMMEND THAT THE BIN IS **NOT** INSTALLED ONTO TARMAC OR BLOCK PAVED AREAS.

DISTANCE FROM EDGE OF FOUNDATION TO CENTRE OF GROUND BOLT TO BE NO LESS THAN 110MM

Permanently sited onto a prepared concrete ground site (20-30N/mmsq) utilising 4 M10x120mm ground fixing bolts which are supplied with your bin.

- 1) Position bin onto siting area ensuring it is the correct distance away from the edge of the concrete (minimum 110mm) and is in the correct orientation with regard to the apertures.
- 2) From the inside of the bin mark hole positions onto the concrete through the fixing holes in the base of the bin with a 12mm diameter masonry drill. Remove the bin.
- 3) Using a 12mm diameter masonry drill bit, drill and clean out anchor holes to a minimum depth of 130mm. Position bin back over the drilled holes.
- 4) Assemble the ground bolts as shown in diagram opposite by removing the 20mm washer and replacing it with the 50mm washer. Drive the ground bolts through the holes in the base of the bin and into the holes in the concrete.
- 5) Tighten nut with correct spanner until fixings are secure. Max recommended torque setting - 20lbs/ft (27Nm).
- 6) In the event of the bin being removed, simply remove the bolt to leave the site hazard free.

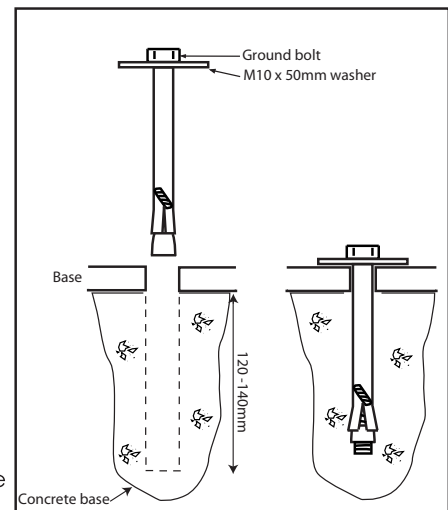

NOTE: For alternative fixing methods please contact us for details.

NEXUS™ 96G

Operating Manual

OPTIONAL Side Connecting Kit

1. Position bins next to each other as shown on right.
2. Open bin doors to gain access to pre-drilled holes within sides of bins.
3. From inside Bin A (see diagram 1 below) using M10 x 25mm bolt and washer provided, push the bolt through the top hole into the hole within Bin B.
4. From inside Bin B, place washer over protruding bolt followed by nyloc nut then tighten.
5. Repeat stages 3 and 4 using the bottom pre-drilled holes to allow the bins to be securely fixed together.
6. From inside Bin A (see diagram 2 below) place the M10 x 180mm bolt and washer through the pre-drilled hole.
7. From outside the bin (rear) place spacer over bolt before pushing into hole in bin B.
8. From inside of bin B, place washer over protruding bolt and secure with nyloc nut.

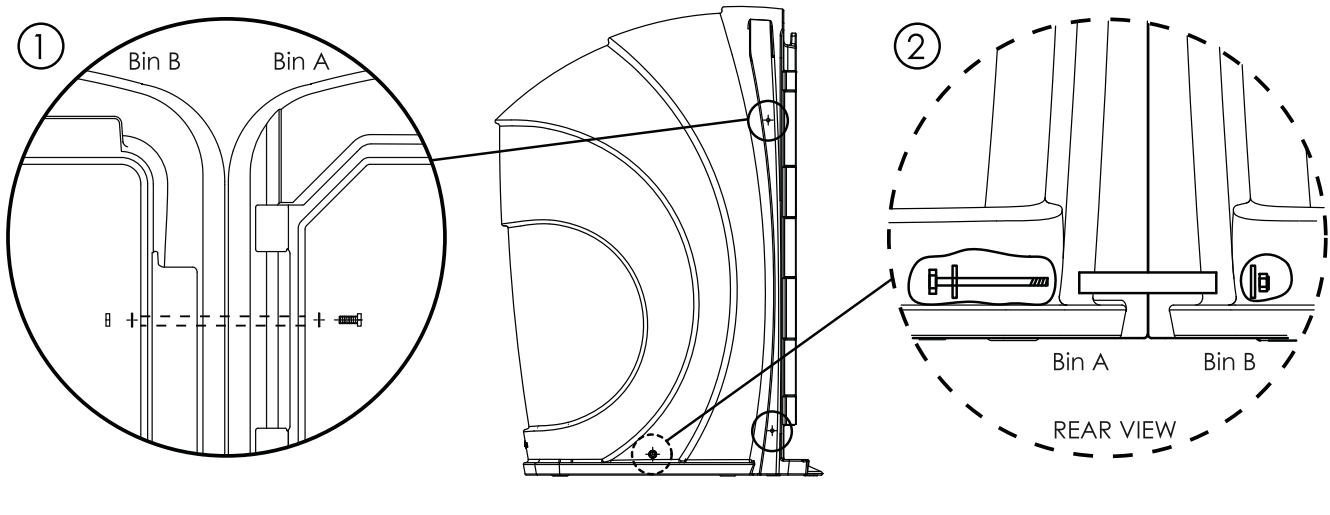
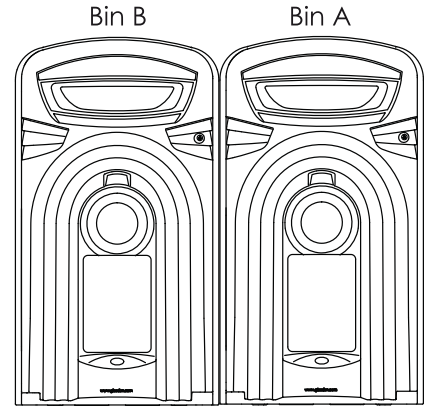

Cleaning Your Bin

We would recommend a warm pressure wash with soap or alternatively hand wash with 10% solution of mild detergent in warm water using a soft bristle brush followed by a rinse with clean water.

Graffiti

Felt tip pen or paint may be removed from Durapol using a proprietary graffiti remover. Carefully follow the instructions, particularly the guidelines covering safety. Ensure that all traces of chemicals are removed then clean as detailed above.

CAUTION:

Graffiti removers can damage stickers, some protection may be afforded by masking off such areas. Please refer to Technical Services for our recommended graffiti removal supplier.

Maintenance

A planned maintenance schedule of regular inspection is recommended and components replaced when necessary.



AND NEXUS ARE TRADEMARKS OF GLASDON GROUP OR ITS SUBSIDIARIES IN THE U.K. AND OTHER COUNTRIES

- A planned maintenance schedule of regular inspection is recommended, replacing components as necessary.
- Replacement components are available direct from GLASDON UK LIMITED.
- GLASDON UK LIMITED cannot be held responsible for claims arising from incorrect installation, unauthorised modifications or misuse of the product.

Issue 4 December 2011 C000/0358

© Copyright 2015

Glasdon UK Ltd reserve the right to alter specifications without prior notice.



Glasdon®

Glasdon, Inc.
5200D Anthony Road
Sandston
VA 23150

Sales Inquiries: 1-855-USGLASDON
General Inquiries: 804-726-3777
Fax: 804-726-3778

E-mail: info@glasdon.com
Web: www.glasdon.com